

CRITICAL: MEASURE FROM TOP OF FINISHED FLOOR OR FLOOR COVERING TO TOP OF TRACK

MEASURE HEIGHT AT SEVERAL PLACES ACROSS THE OPENING

ALL DIMENSIONS IN PARENTHESES ARE MILLIMETERS.

NOTES:

- Headers prepared by others to carry concentrated live load of partition(s) across entire opening.
- See specifications for lbs. per sq. ft. Headers must be level. Sway bracing, if required, by others.
- At poured concrete floors, place screeds to hold variation to no more than 1/4" (6), plus or minus, in 10'-0" (3048), non-accumulative, 16" (406) either side of center line of track.
- All grounds for jamba to be plumb to 1/4" (6), plus or minus, from finished floor to top of track.
- All structural requirements and trim, except jamb mould or ceilingguard by others.

SURFACE TRACK WITH WOOD MOLDING
BY WOODFOLD
4166

NOTE: # 14 X 2" (51) S.M. TRACK SCREWS

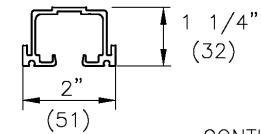
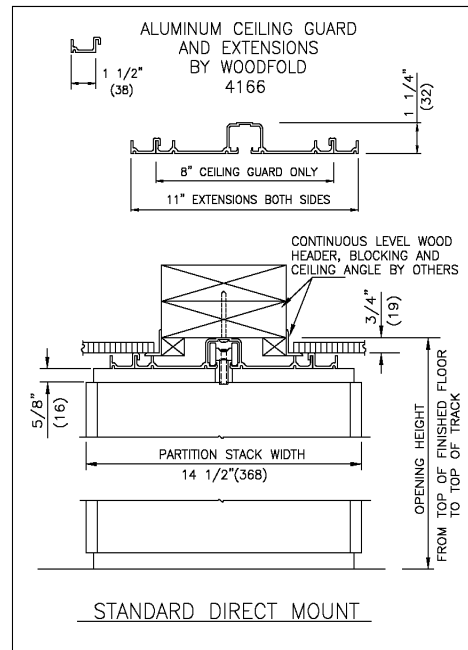
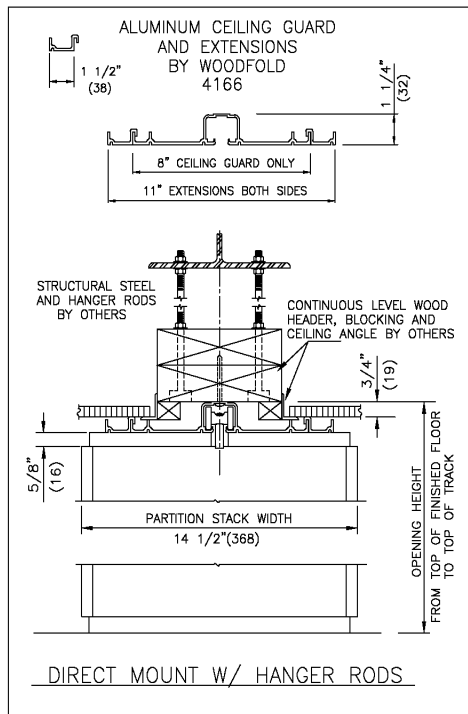

CONTINUOUS LEVEL WOOD HEADER AND BLOCK NOT BY WOODFOLD

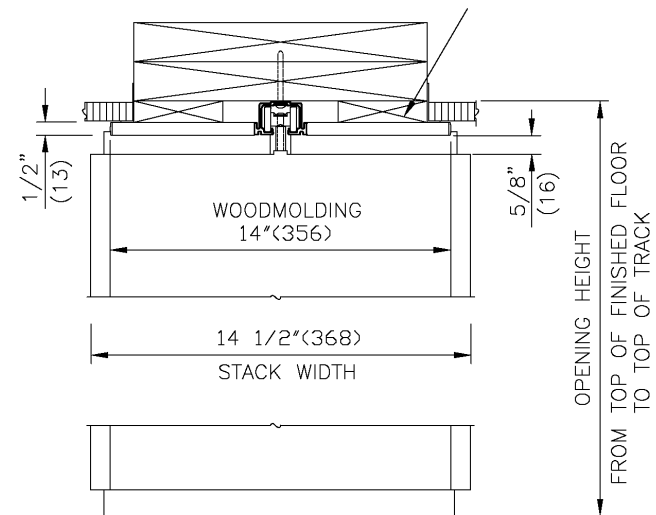

PROJECT:

DATE

Single Fixed (Left Hand)-Jamb Partition

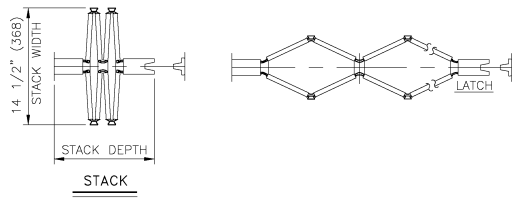

Single Fixed (Right Hand)-Jamb Partition

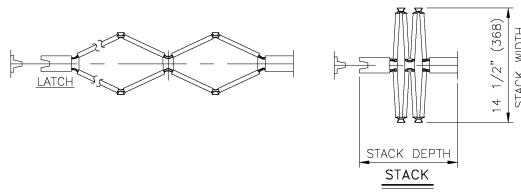

Double-End Post Partition

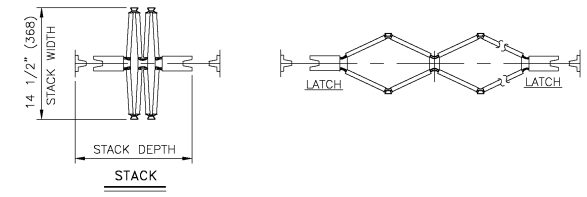

LEAD POST/JAMB MOLDING
WOODFOLD 4166/4188

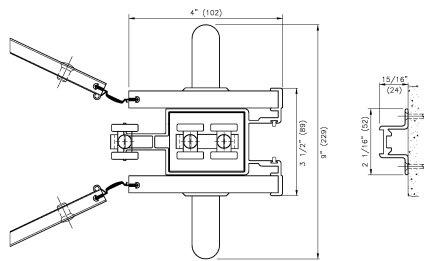

Joining Pair Of Fixed-Jamb Partitions

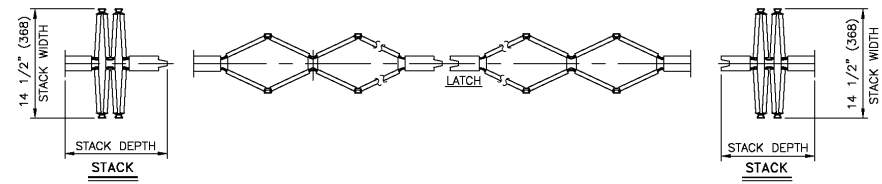

POST MOUNT
WOODFOLD 4166/4188

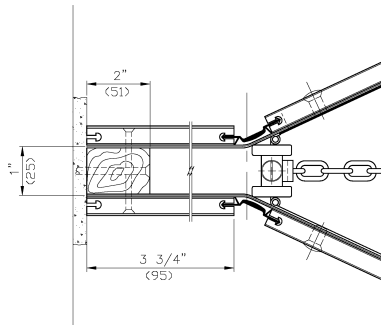

Sliding Jamb Partition-Pocket Installation

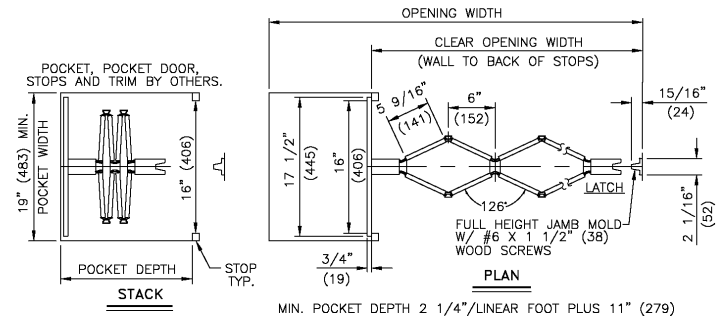

WOODFOLD 4166



Woodfold Mfg, Inc.
Forest Grove, OR

PROJECT:

DATE

SHEET 2 OF 2