

Surface Track

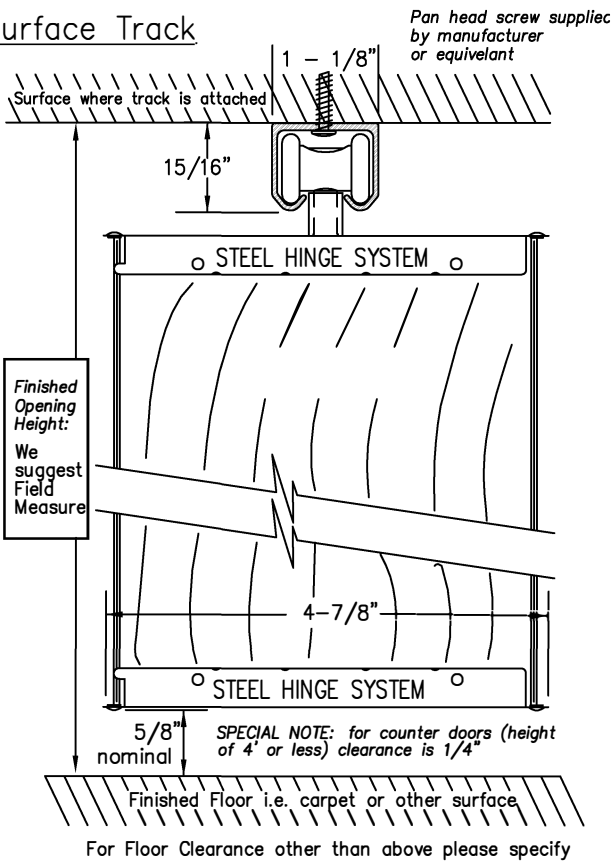

Recessed Track

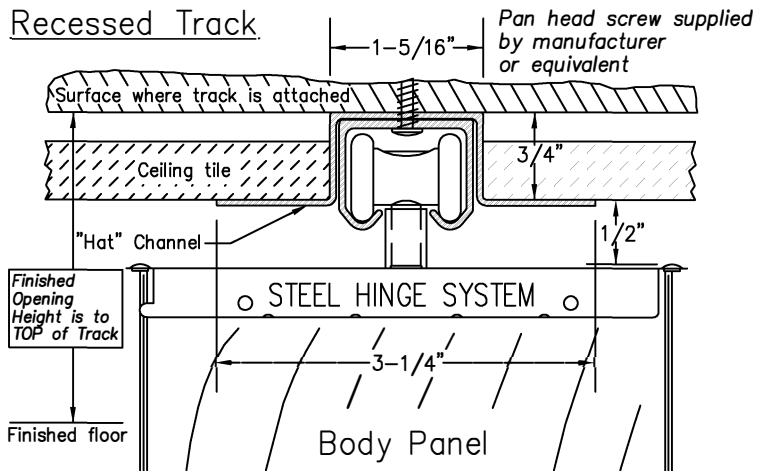

I-Beam Track

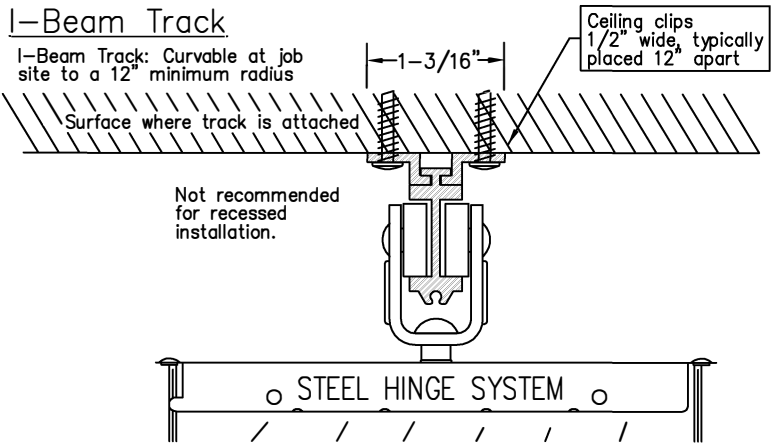

Door Types

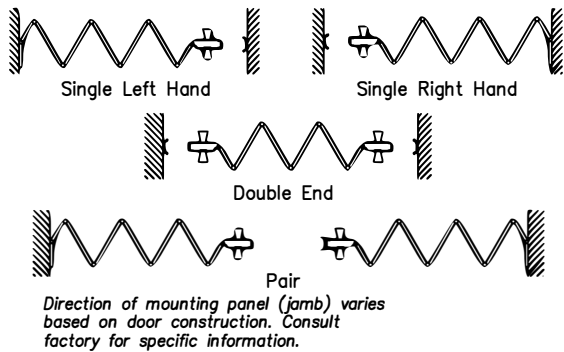

Lead Post, Jamb Mouldings & Handle

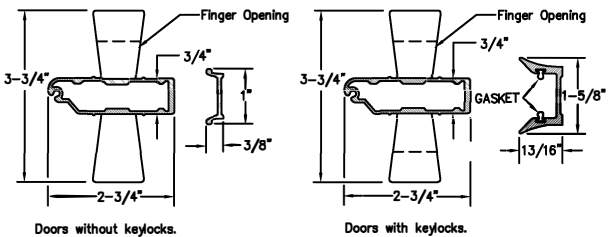

Sliding Jamb Option

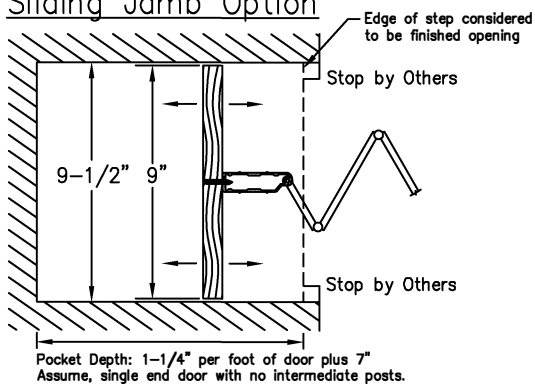

Mounting Panel

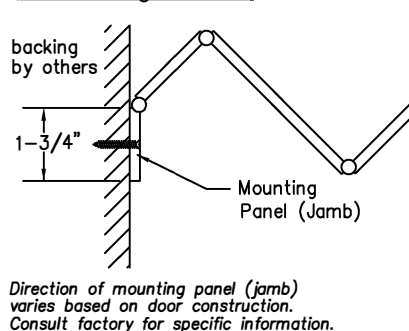

Multiple Meeting Option

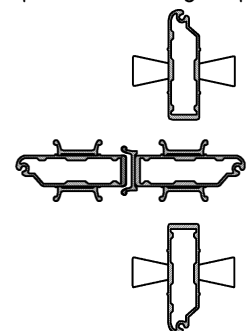

Stack Dimensions

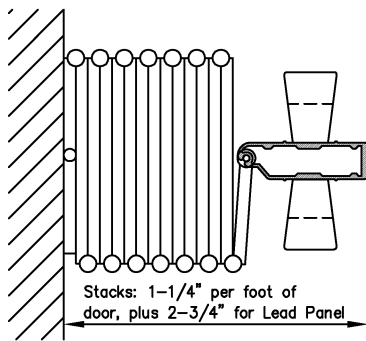

Stacks: 1-1/4" per foot of door, plus 2-3/4" for Lead Panel

Intermediate Rolling Post

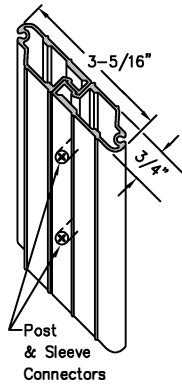

Privacy Latch



Keylock

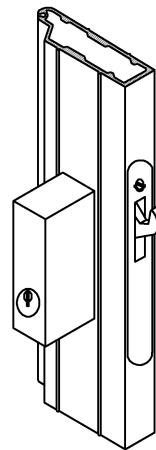

Single Cremone Bolt Keylock

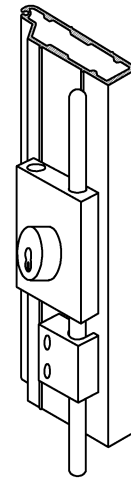

Double Cremone Bolt Keylock

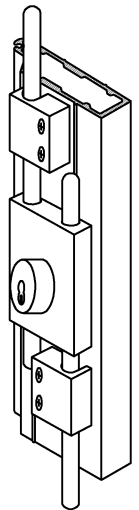

INFORMATION

Width	Custom made to any width
Height	Vinyl lam custom made to 10' -1" Hardwood veneer custom made to 10' -1"
Panels	Natural hardwood or vinyl-lam on MDF core
Panel Connector	Extruded Vinyl: White, Brown or Sand
Hinge System	Steel: Dark Bronze or Clear
Wheels	Ball bearing nylon wheels on steel axles
Track	Aluminum (straight or curvable): Dark bronze or Clear
Recessed Channel/ "Hat" Channel	Aluminum (straight only): White
Lead, Intermediate and Jamb	Aluminum: White, Brown or Sand Coordinated with panel connector
Latch	Deadlatch with thumb turn two sides
Header	Constructions Details by Others
Door Weight	<u>Height</u> <u>Average Weight</u> 6'-8" 10lbs. Per lined foot 8'-1" 12lbs. Per lined foot 10'-1" 15lbs. Per lined foot

Catch/Lock Options

Magnet	Magnet with strike plate
Privacy Latch	Deadlatch with thumb turn one side
Springlatch	Springlatch with thumb turn two sides
Keylock 1 Side	Deadlatch with thumb turn one side, keylock one side
Keylock 2 Side	Deadlatch with keylock two sides
Single Cremone	Single cremone bolt with keylock
Double Cremone	Double cremone bolt with keylock
Footbolts	Locking or non locking
Other Keyed Options	Keyed alike, custom keyed, construction core Contact manufacture for more details

Job Name: _____ Architects Acceptance

Job Location: _____

Supplier: _____

See Woodfold Accordion Door brochure for additional details

Qty.	Single End/Double End	Left or Right Stack	Width X Height	Finish/Color	Comments

THESE SPECIFICATIONS ARE SUBJECT TO CHANGE WITHOUT NOTICE